



A.D. METAL INDUSTRY VRANJE  
Radnička 1

## SOLID FUEL STOVE

### Gala



## INSTALLATION, OPERATION AND MAINTENANCE MANUAL



*The product meets the Ecodesign Directive requirements related to the degree of efficiency and air pollution level in order to reduce energy consumption and negative effect to the environment.*

## Content:

1.	MANUFACTURER / PRODUCT TYPE .....	1
1.1.	Manufacturer .....	1
1.2.	Technical Data .....	1
2.	USER MANUAL .....	1
2.1.	Introduction .....	1
2.2.	Inspection at Delivery .....	2
2.3.	Precautions .....	2
2.3.1.	Adequate Fuels .....	2
2.3.2.	Inadequate Fuels .....	2
2.4.	Fire Hazard .....	2
2.5.	Human Being Is No Filter .....	2
2.6.	Warnings .....	2
2.7.	BASIC USER CHARACTERISTICS .....	2
3.	STOVE DESCRIPTION .....	3
3.1.	Increased Functionality with More Simple Regulator .....	3
4.	STOVE INSTALLATION .....	3
4.1.	Possibility of Connecting Flue Gas Pipe to the Back Part of Stove .....	3
4.2.	VENTILATION AND COMBUSTION INSTRUCTIONS .....	4
5.	LIGHTING FIRST FIRE .....	5
5.1.	Ignition Procedure .....	5
5.2.	Heating .....	6
5.3.	Fuel Injection .....	6
6.	STOVE CLEANING .....	7
6.1.	Warnings .....	7
6.2.	Warning .....	7
7.	ASSESSMENT OF NECESSARY THERMAL POWER .....	7
8.	DEVICE SHUTDOWN .....	7

# 1. MANUFACTURER / PRODUCT TYPE

## 1.1. Manufacturer

Alfa – Plam a.d.  
Radnička 1  
17 500 VRANJE  
SERBIA

Tel.: +381 17 421 121  
Fax: +386 17 421 552  
Email: [firma@alfaplam.rs](mailto:firma@alfaplam.rs)

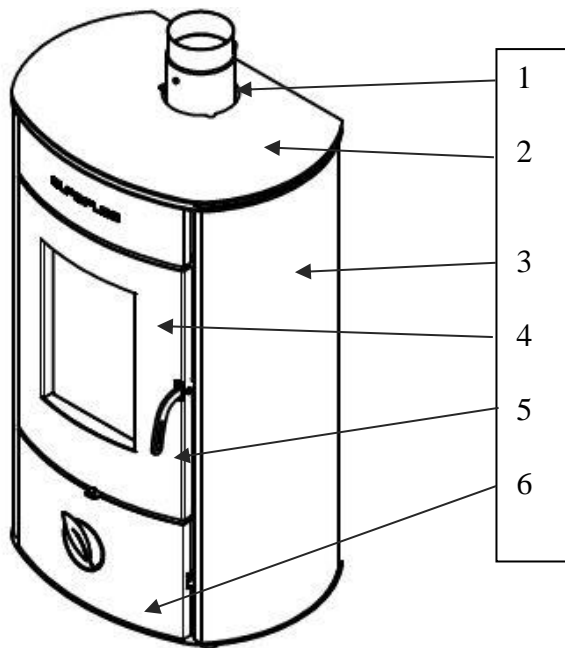

Image 1 Solid Fuel Stove

1. Flue gas extension
2. Panel
3. Side
4. Door
5. Handle
6. Bottom portal

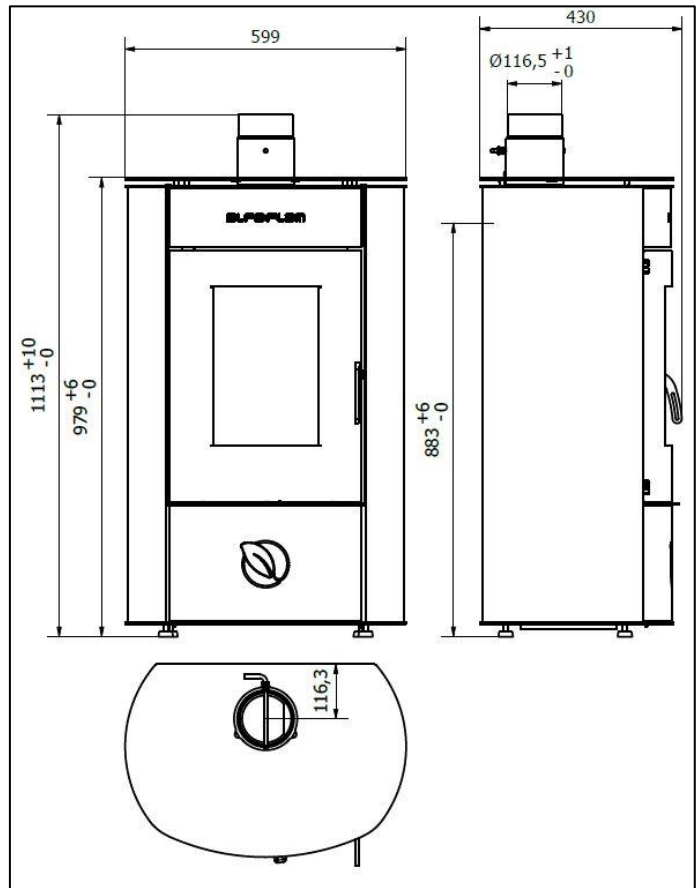

Image 2 Dimensions

## 1.2. Technical Data

PRODUCT TYPE	GALA
- Stove dimensions	
- width	599 mm
- depth	430 mm
- height	979 mm ...(with flue gas extension 1113 mm)
Nominal heat output	8.00kW
Diameter of flue gas pipe connection	Ø118 mm
Necessary pressure to the chimney	12 Pa
Stove weight	97 kg
Efficiency	76.4 %
Chimney connection	from above and behind
Distance between the floor and flue pipe connection axis behind	889 mm
Flue gas flow rate	9.2 g/s
Flue gas temperature	253.7 ° C
CO-emission in relation to 13 % O <sub>2</sub>	0.0675 %
CO <sub>2</sub> content	7.71 %
Standard	EN 13240:2011

# 2. USER MANUAL

## 2.1. Introduction

Thank you for the purchase of ALFA - PLAM stove.

Please take some time to carefully read the manual.

For the proper stove operation and valid warranty certificate please observe the recommendations and guidelines in the manual.

If you have any further questions not covered by the manual, please contact the local stove vendor or stove service.

Proper use and maintenance are preconditions to long and flawless stove operation.

The device is not intended to be used by persons (including children) with diminished physical capacity, motor skills and mental capacity, or persons with limited knowledge and experience without the presence of person in charge of their safety or under care.

## 2.2. Inspection at Delivery

- First inspect the stove for defects or damages.
- Pay special attention to the glass and doors.
- Upon the stove use the most often damages to the glass are mainly caused by incorrect handling.
- Prior to the installation check the functionality of all movable parts. For potential damages contact your local vendor.

## 2.3. Precautions

- Warning! Heated metal parts and glass could cause burns, therefore during the stove operation use protective gloves.
- Undertake special protection measures if children are near.

### Fire Safety Measures inside the Radiation Field

- Minimum distance from the fire opening close to flammable items (e.g. pieces of furniture, alcoholic beverages), should be greater than 100 cm.
- Minimum distance of elements from the back part and sides should be greater than 40 cm.

### Fire Safety Measures outside the Radiation Field

- Do not place any combustibles at a distance less than 50 cm in relation to the open stove.

### 2.3.1. Adequate Fuels

The stove is designed to combust fuel found in nature (e.g. beech, birch), wooden briquettes and coal briquettes.

Beech has among the best calorific values compared to other fuels, as well as good combustion properties (if dried and stored properly).

Freshly chopped wood must be dried, mostly 12 to 18 months before their use (it is recommended that wood is dried outside, protected from rain). Fuel moisture content should not exceed 20%.

Beech, birch and oak burn with stable flame and produce long-lasting ember.

Coniferous trees (e.g. pine tree, fir) smell nice, burn fast, crackle and produce sparks, but are rich in resin, which could have adverse effect both to the stove and the chimney (cause the obstruction of flue ducts).

### 2.3.2. Inadequate Fuels

It is forbidden to burn the following materials in the stove:

- Saturated or damp wood,
- Plywood,
- Materials of animal origin (hoofs, horns, etc.),
- Coal dust
- Plastic waste and household waste,
- Paper and cardboard (except if used as kindling)

Please have in mind that burning any waste is dangerous to your health, given that it leads to environmental pollution. It also results in poor stove combustion and shorter service life.

## 2.4. Fire Hazard

Waste disposal inside the stove, as well as waste combustion not only raises the question of health or service life, but also poses as problem in connection with taking fire precautions. In general, if the stove is not operated properly (regular cleaning, combustion of appropriate materials etc.) it could cause fire.

In case of fire due to improper use, the user shall be deemed legally responsible.

## 2.5. Human Being Is No Filter

Many flammable residues (e.g. wood, paper, blend etc.) contain heavy metals (Cd, Pb, Zn, Cr etc.) and halogens (e.g. Cl, F etc.). With their combustion toxic gases such as nitric oxide, hydrochloric acid, hydrocarbon and dioxin could be emitted, therefore polluting the environment.

## 2.6. Warnings

- It is not allowed to wall up or change the stove (by adding/removing material)
- Pay special attention regarding air supply and the connected regulation (air regulator). Whenever you are handling the stove use the protective gloves to avoid possible burns.
- Never use gasoline, alcohol or similar substances to ignite the fire.
- Do not overload the stove (maximum 2-3 pieces of wood for lighting fire and 2.5 kg/h in case of continuous burning).
- Always use the recommended fuel. This is important in connection with the validity of warranty certificate.
- All damaged parts should be replaced before the first use.
- Chimney connected to the stove must meet requirements provided by the user manual.
- To connect the device with the chimney, you should by no means use flexible hose instead of flue gas pipes.
- Regular maintenance and care, such as cleaning the stove, flue gas pipes and nozzles is important for safe operation, especially to the cost-effectiveness and maintenance of stove value.
- Unauthorized modifications to the device are forbidden, as every such repair shall violate the warranty.

## 2.7. BASIC USER CHARACTERISTICS

User of stove must be adult and responsible person with technical knowledge necessary for regular maintenance of mechanical and electric parts to the stove.

Be careful not to let children come close to the stove while in operation, with the intent to play.

Children may not come close to the stove while in operation, with the intent to play. The device can be used by children age 8 and above, as well as persons of diminished physical, sensory or mental capacity, provided that they are supervised by seniors familiar with the user manual. Stove cleaning and maintenance cannot be performed by children without the supervision of senior.

### 3. STOVE DESCRIPTION

- The stove is made of metal and has closed combustion chamber.
- The stove can be placed anywhere in the room (next to wall, in the corner etc.), provided that the floor is even. No permit is necessary to install the stove.
- Our stove provides the sensation of at your home by pure combustion and heating of room.

#### 3.1. Increased Functionality with More Simple Regulator

- During the stove operation, a layer of embers is produced in the combustion chamber, which provides even combustion of fuel.
- With the regulation of primary and secondary air supply based on the air regulator (Image 12, 14 and 16), discharge of temperature from the stove can be controlled indirectly.

### 4. STOVE INSTALLATION

The stove should be placed on firm, horizontal surface at minimum distance to the back and on sides -40 cm, to the front-100 cm (Image 3). The surface **MAY NOT** be made of any easily flammable material (linoleum, carpet, wood etc.) and it should be connected to the chimney in accordance with the national regulation. Stove connection to the chimney could be performed from above (factory setting) or from the back. Packed together with the device is the flue gas extension integrated to previously installed flue gas connector for better use of combustion product. To the existing flue gas connector (Image 4. detail d) fix the tape (Image 4. detail b) (packed together with flue gas extension and sheet metal screw) along the rim, above the existing screw holes and place the flue gas extension (Image 4. detail a) to make an impermeable joint as in Image 4. Set the safety screw (Image 4. detail c).

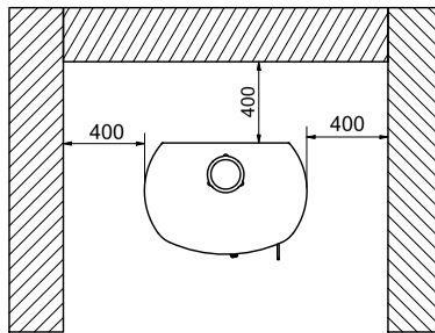

Image 3

#### 4.1. Possibility of Connecting Flue Gas Pipe to the Back Part of Stove

The stove is factory set for the outlet of flue gases upwards, but if suitable the outlet of flue gases could be at the back. Change of outlet can be done according to the instructions:

- Lift the top plate – assembly (Image 4a, item 1)
- To the back part of stove with the use of pliers cut thin strips that hold the lid (Image 5)
- Undo the screws and nuts from the flue gas connector and lid at the back of chamber (Image 6, item 2 and 3)
- Set the flue gas connector at the back of chamber, paying attention that the sealing strip fits properly, and affix with screws and nuts (Image 7, item 3)
- Place the lid to the upper part of chamber, paying attention that the sealing strip fits properly, and affix with screws and nuts (Image 7, item 2)
- Put back the top plate – assembly (Image 10, item 1) to the place, making sure that the supports (Image 8, item L) fit into the holes at the lower part of top plate - assembly
- Position of the lid upon the delivery of stove (Image 9, item 4)
- Place the lid to the appropriate place on the top plate – assembly (Image 10, item 4)

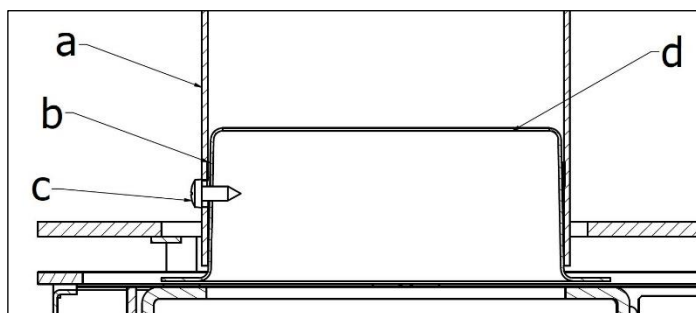

Image 4

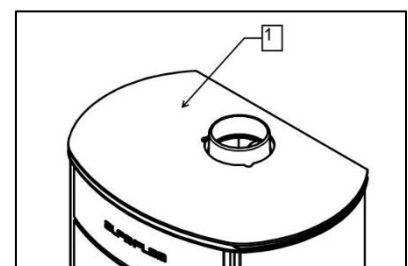

Image 4a

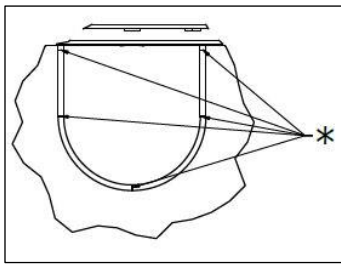

Image 5

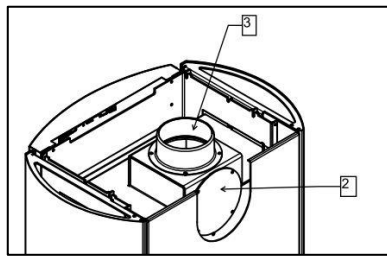

Image 6

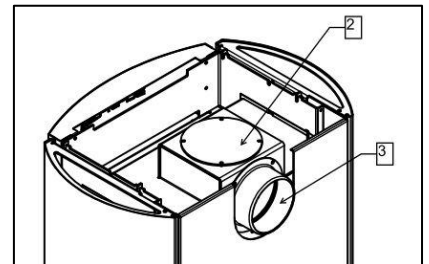

Image 7

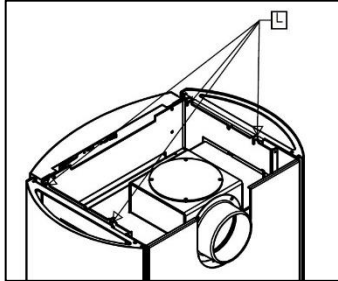

Image 8

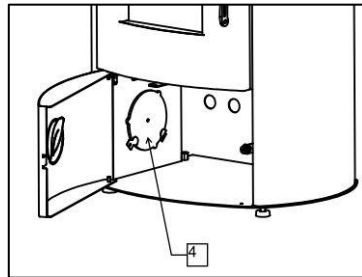

Image 9

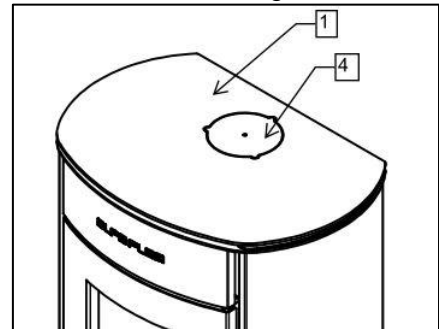

Image 10

## 4.2. VENTILATION AND COMBUSTION INSTRUCTIONS

Combustion air must be supplied to the rooms where the stove is installed. The room should be ventilated continuously. Fresh air inlet should be located at the bottom of room, with the air passing inside the inlet.

A) Combustion air supply via pipeline in a basement. For such connection option, the combustion air is heated previously, which is useful regarding good and clean combustion. The installation of pipeline in the basement is simple.

B) Combustion air supply via basement. The combustion air is heated previously. The basement space should be separated from the ventilation system in the house and with external openings. Avoid high levels of dust and moisture.

V) Combustion air supply from above. Air supply from above can be done only with inspected chimney systems.

In this case it is necessary to calculate the exact size of chimney!

D) Combustion air supplied directly outside. If the air supply comes directly via external wall, the combustion air is only slightly preheated, which is unfavorable to clean combustion. In this case there is also a risk of condensation!

NOTE: These options of air supply are not recommended! However, if such options are implemented, contact qualified expert.

The room with installed heating device must be supplied with sufficient fresh air. If windows and doors are sealed hermetically or the room with the installed stove contains devices such as hood, hair dryer, fan etc., which extract the air, the combustion air (fresh) must be supplied externally. In any case, the issue should be discussed with the competent chimney sweeper before the stove installation.

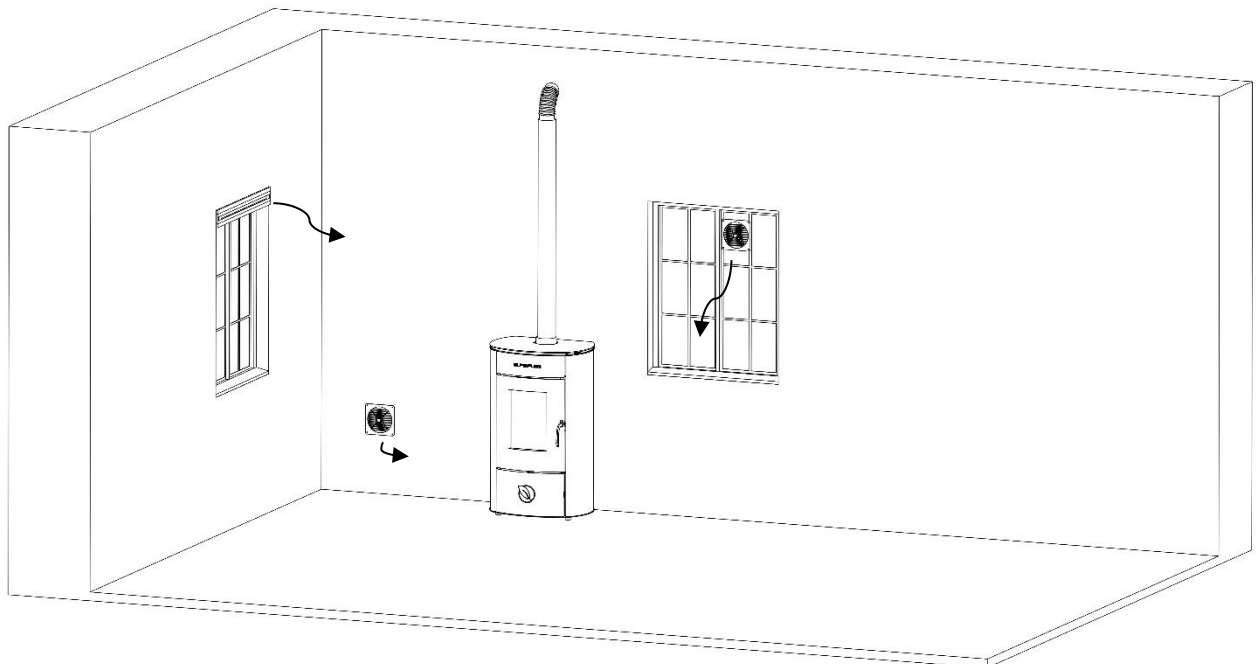

Fresh air supply to the room with installed stove

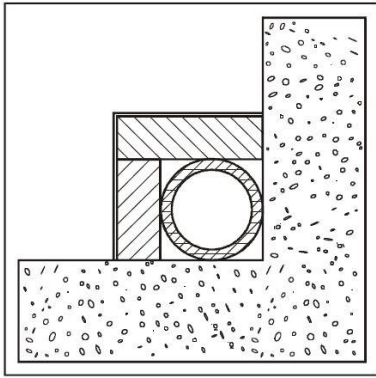

Steel chimney AISI 316 with double insulated chamber, material resistant to 400 ° C. Optimal efficiency 100%

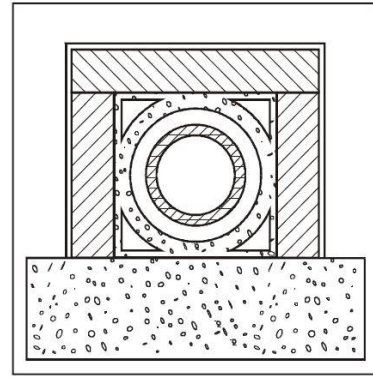

Fireproof chimney with double insulated chamber and external lightweight concrete cladding. Optimal efficiency 100%

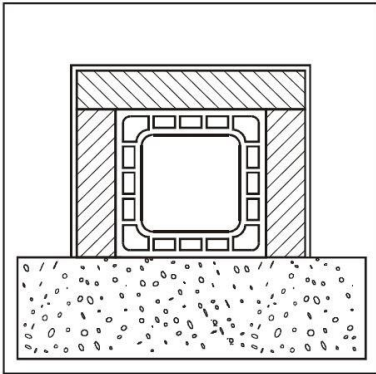

Standard chimney made of clay with recesses. Optimal efficiency 80%

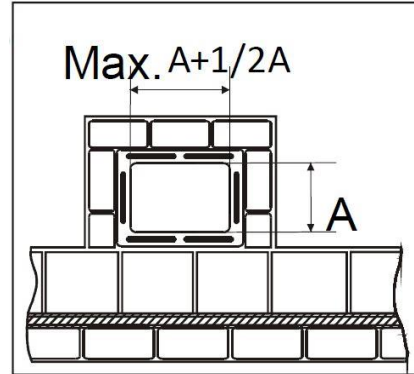

It is forbidden to use chimney pipes with rectangular cross section, whose aspect ratio is different from the plan. Moderate efficiency 40%

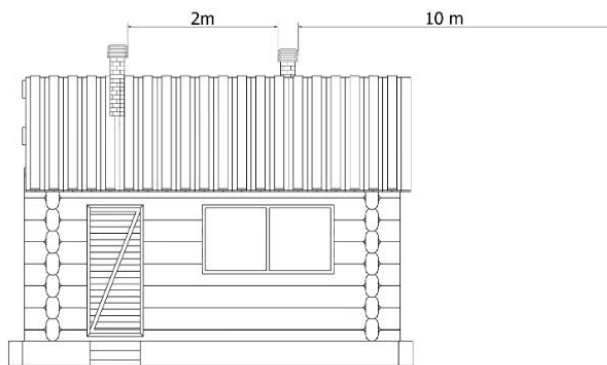
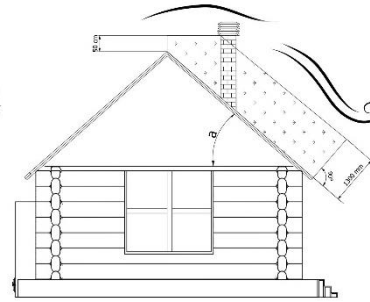
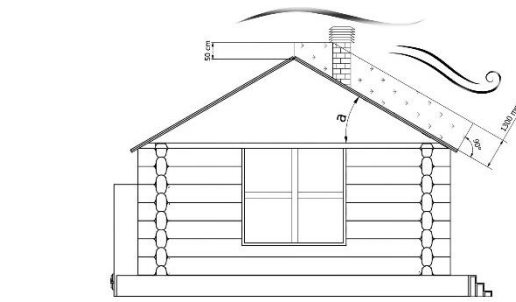

Chimney – positioning and distance

## 5. LIGHTING FIRST FIRE

After the stove installation and connection to the chimney, first lighting of fire should be done by authorized person (chimney sweeper).

- Commence with low intensity fire. All materials must be exposed to the temperature gradually to stop fuel crackling, damages to the coating and material (binding).
- Ventilate the room thoroughly. If there is a smell during the first firing – that is normal phenomenon due to stabilization of painted parts. In the following firing the smell shall fade gradually.

### 5.1. Ignition Procedure

- Position the air regulator to provide the supply of primary and secondary air simultaneously, the final position to the left (view image below, Image 12).
- Set the regulator handle on the flue gas extension to the position as in Image 13 (along the flue gas extension).

- Open the door.
- After placing materials to be ignited (thin wood, ignition cubes, creased paper...) at the combustion chamber add 2-3 pieces of wood (chopped) on top. Fill in the stove carefully to avoid possible damages.
- Ignite flammable materials and close the stove door.
- Once the stove is heated (mostly in 5 to 10 minutes), close the primary air inlet (Image 14) by setting the regulator to optimal position; Make sure that the parts of the oven are already heated and that a protective glove should be used;
- Turn the regulator handle on the flue gas extension transverse to the pipe axis (Image 15). Keep in mind that the parts are already heated; therefore protective gloves should be used.
- Heat discharge is regulated by opening or closing the secondary air inlet.
- Nominal heat output (8 kW) is generated when the air regulator is positioned, so that a small circular hole on the regulator and a small channel on the door are aligned (Image 14)

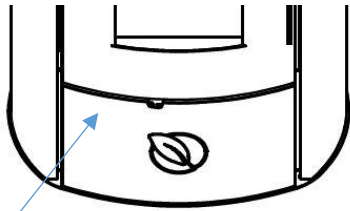

*Image 12*  
Regulator to the left  
Both primary and secondary air inlets are fully opened

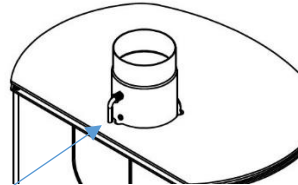

*Image 13*  
Regulator handle along the pipe, regulator is open

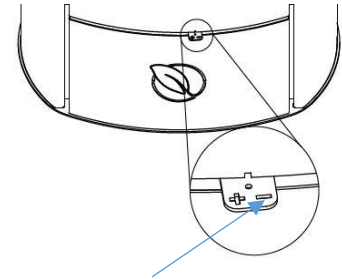

*Image 14*  
Hole on the regulator in the middle is aligned with the channel on bottom section  
Secondary air inlet is optimally open

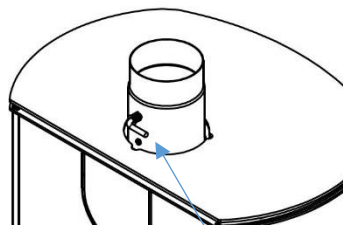

*Image 15*  
Regulator handle transverse to the pipe axis, the regulator is closed

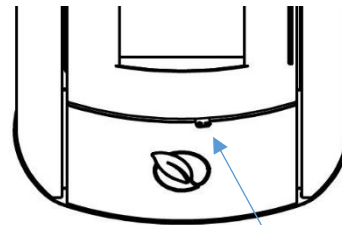

*Image 16*  
Regulator to the right  
Both primary and secondary air inlets are fully closed

- approximately 2.5 kg fuel in the combustion chamber (firebox)
- 12 Pa draught
- Certain quantity of air heated inside the stove is transferred through the channels onto the door glass, used for cleaning the glass (airbrush cleaning).

**Attention:** Stoves require slightly longer ignition phase occasionally until there is sufficient negative pressure (draught), so the stove could operate independently. In that case, use smaller fuel parts. Later you can use bigger as well.

If the doors are open in the course of lighting fire, a powerful draught could cause fire to flare up.

## 5.2. Heating

- Maximum capacity of firebox is 2.5 kg fuel per hour.
- Leave the fresh air inlet open (if available).
- Fire intensity is regulated by secondary air inlet: the position of circular hole in the middle of regulator is aligned with the door channel (Image 14);
- By turning the regulator to the right (Image 16) both primary and secondary air inlets are closed;

## 5.3. Fuel Injection

- Every time the door is opened you should always wear protective gloves.
- Open the door slightly and wait 3-4 seconds, and then open the door fully and with care to prevent the emission of flue gases from the chamber.
- Remember that the maximum capacity is 2.5 kg fuel per hour.
- Close the door.
- Always keep fire under control to prevent possible fire accidents. Pay special attention if children are near.

## 6. STOVE CLEANING

### 6.1. Warnings

- Cleaning should be done once the stove has cooled down completely. Remember – ember can remain in the ashes for hours after the fire has been put out.
- Every time you clean always wear protective gloves.
- Open the door.
- Remove the residue from the combustion chamber.
- Glass should be cleaned with special cleaning agent (contact your local vendor in connection with the cleaning agent).
- If the stove is used properly, the glass should be clean (There is a possibility that the glass gets dirty and sooty if the fuel is damp, the chimney is inadequate –insufficient draught etc.).

#### What happens if...

- ... there is not enough supply of fresh air?
  - Is the air inlet closed?
  - Is the combustion air regulator closed?
- ... the fire is extinguished on its own or is poorly ignited?
  - Is the air inlet closed?
  - Is the combustion air regulator closed?
  - Is there enough supply of fresh air?
  - Is the fuel damp?
  - Do you use chopped wood?
- ... the room is not heated sufficiently?
  - Is the combustion air regulator closed?
- ... the stove is overheated?
  - Is the primary combustion air inlet fully open?
- ... the glass gets sooty too quickly?
  - Fuel contained too much moisture.
  - The supply of fresh air was insufficient.

### 6.2. Warning

- *Repairs to the stove may be performed only by qualified and trained staff. Reading the manual cannot make you an expert. In case of any problems similar to the above mentioned, please contact the local service or a chimney sweeper.*
- *The space under the chamber is not intended for storage of flammable material.*

## 7. ASSESSMENT OF NECESSARY THERMAL POWER

There is no absolute rule that could provide the assessment of necessary thermal power. The strength is determined by the space to be heated, however it depends on the insulation to great extent. On average, thermal power necessary for properly insulated room would be **30 kcal/h at m<sup>3</sup>** (for external temperature of 0 ° C).

Fuel	Unit	Indicative combustion value		Necessary quantity against 1 kg of dry wood
		kcal/h	kW	
Dry wood (15% moisture)	kg	3600	4.2	1.00
Damp wood (50% moisture)	kg	1850	2.2	1.95

## 8. DEVICE SHUTDOWN

In case of fire or overheating, close the lids to the air inlet and do NOT open the door. Extinguish fire with the appropriate devices (home fire extinguisher etc.). NEVER USE WATER TO EXTINGUISH THE FIRE! In case of fire you should also notify the local firefighters. Observe the local fire protection regulations!