



A.D. METALNA IDUSTRIJA VRANJE
Radnička br: 1

Solid fuel stove

ALFA 85 G



Instructions for installation and handling



This product meets the requirements of the Ecodesign Directive in terms of efficiency and air pollution level, in order to contribute to the reduction of energy consumption and negative environmental impact.

ENG_v.1.0

1611845



Figure 1

ALFA 85 G Solid Fuel Stove

1. Firebox door
2. Ashtray door
3. Air control
4. Fuel drawer
5. Lateral connection for the flue pipe
6. Double-glazed oven door
7. Protective cover of the opening for cleaning

INSTRUCTIONS FOR INSTALLATION, USE AND HANDLING

These instructions for installation, use and handling are applicable to the following type of stoves:

ALFA 85 G

When using the stove you must observe both national and European standards and regulations.

Important before use

- * To make your stove function properly, it is important that you read this manual carefully and observe the instructions contained herein.
- * Use only recommended types of fuel, beech, lignite.
- * Pressure in the chimney at the normal operating load should be approximately 12 Pa. For load above 15 Pa, a baffle should be built in the stove-pipe.
- * Sufficient fresh air should be provided in the room where the fuel installation is located. If the windows or doors seal properly or if other appliances such as a steam cleaner, tumble dryer, a fan, etc. are located in the area where the stove is installed and subtract the air, under such circumstances, the burning air (fresh air) should be brought from outside. In this regard, in any case, a competent chimney sweeper should be consulted before installing the stove.
- * Combustible materials should not be kept in the ashtray. The height of the ash filled should not exceed the height of the side walls of the ash drawer.
- * The door of the firebox and the door of the ashtray should be kept closed all the time (except during lighting the fire in the stove, refilling the fuel and removing ash) to prevent the escape of gases from combustion.
- * Parts of the stove should not be replaced unless they are tested original parts and accessories offered by us or by our service.
- * If the chimney sets on fire, keep the door of the stove closed and set the air control to zero. Never try to extinguish the burning chimney with water. The sudden creation of water vapour can lead to the chimney cracking. If necessary, call the fire brigade.

 **CAUTION**

- MAKE SURE TO USE FIREWOOD WITH A HUMIDITY PERCENTAGE OF LESS THAN 25% OR FIREWOOD THAT HAS BEEN STORED IN A DRY AND OPEN SPACE FOR TWO YEARS.
- The minimum installed power of the heating system must not be less than 65% of the nominal power of the stove and the maximum installed power of the heating system must not be more than 100% of the nominal power of the stove.
- The chimney, to which the range is connected must meet the requirements provided in the user manual.
- When connecting the appliance to the chimney, never use flexible hoses instead of flue pipes.
- Regular maintenance and care, such as cleaning the range, the flue pipes and the nozzles (of the pipes), are important to ensure safety, and especially for the sake of economy and in order to maintain the value of the range.
- Unauthorized modification of the device is prohibited and therefore any unauthorized modification shall render the warranty null and void.

Content:

1.	TECHNICAL DATA	1
2.	THE RESPONSIBILITY OF THE MANUFACTURER	1
2.1.	THE BASIC CHARACTERISTICS OF THE USER	1
2.1.	THE TRANSPORTATION AND USE OF THE STOVE – HANDLING	1
2.2.	THE RESPONSIBILITY OF THE INSTALLER.....	1
3.	STOVE INSTALLATION	2
3.1.	AIR USED FOR COMBUSTION	2
4.	INSTALLATION TO THE FLUE	3
5.	HANDLING	5
5.1.	HANDLING OF THE FIREBOX DOOR HANDLE	5
5.2.	AIR CONTROL	5
5.2.1.	PRIMARY AIR	5
5.3.	WARMING FLAP	6
5.4.	OVEN DOOR (Figure 1, Item 6)	6
5.5.	FUEL DRAWER (Figure 1, Item 4)	6
6.	COMMISSIONING OF THE STOVE	6
6.1.	LIGHTING THE FIRE	6
6.2.	ADDING THE FUEL	6
6.3.	COOKING.....	7
6.3.1.	COOKING IN THE SUMMER	7
6.3.2.	COOKING IN THE WINTER	7
6.4.	BAKING CAKES AND ROASTING	7
6.5.	FIRING THE STOVE IN THE TRANSITION PERIOD	7
7.	MAINTENANCE AND CLEANING OF THE STOVE	7
7.1.	OPENING FOR CLEANING	8
7.2.	MAINTENANCE AND CLEANING OF THE COOKING PLATE	8
7.3.	REMOVAL OF SLAG AND ASH.....	8
7.4.	GENERAL NOTES	8
8.	DETERMINING THE REQUIRED HEAT OUTPUT	8
9.	TURNING THE APPLIANCE OFF	8

1. TECHNICAL DATA

UNIT		ALFA 85 G
Nominal heating capacity	(kW)	8,31
Mass of the flow of waste gases	(g/s)	8,85 for split firewood
Temperature of of waste gases	(° C)	161 for split firewood
Required pressure in the chimney	(Pa)	13
CO ₂ content	(%)	0,08 for split firewood
Stove dimensions(width x depth x height)	(mm)	845x613x867
Oven dimensions (width x depth x height)	(mm)	460x440x260
Flue diameter	(mm)	120
Height from the floor to the flue axis	(mm)	laterally 690
Weight	(kg)	110
Connection		multiple

2. THE RESPONSIBILITY OF THE MANUFACTURER

Upon publishing this Manual, ALFA PLAM will not accept any civil or legal responsibility, either direct or indirect, due to:

- Accidents occurred due to the non-observance of the standards and specifications stated in this Manual,
- Accidents occurred due to the improper operation or use of the stove by the user,
- Accidents occurred due to any modifications and repairs not approved by ALFA PLAM,
- Poor maintenance,
- Unpredictable events,
- Accidents occurred due to the use of spare parts that are not original spare parts or that are not intended for these models of the stove.

The installer of the stove shall take the full responsibility for the installation.

2.1. THE BASIC CHARACTERISTICS OF THE USER

The stove must be used by adult and responsible people.

Make sure that children do not approach the stove, when it is in use, with the intention of playing.

Children must not approach the stove, while in function, with the intention of playing. This appliance can be used by children aged from 8 years and above and persons with reduced physical, sensory or mental capabilities or lack of experience and knowledge. If they are supervised by an elderly person who is familiar with the instructions of use. Children cannot carry out the cleaning and maintenance of the stove, if they are not supervised by an elderly person.

2.1. THE TRANSPORTATION AND USE OF THE STOVE – HANDLING

During the use of the stove care should be taken that the stove is not leaned forward because the centre of gravity of the stove is oriented forward.

While moving the stove, which must be carried out absolutely safely, ensure that the forklift truck has a carrying capacity that is higher than the weight of the stove it should lift. Avoid twitches and abrupt movements.

ALL THE PACKAGING MATERIAL SHOULD BE REMOVED AWAY FROM THE REACH OF CHILDREN AS THE MATERIALS CONTAINED IN THE PACKAGING MAY CAUSE SUFFOCATION. THESE INCLUDE PLASTIC BAGS, FILMS, STYROFOAM, ETC.

2.2. THE RESPONSIBILITY OF THE INSTALLER

The responsibility of the installer is to perform all the checkups of the flue piping, air intake/supply, as well as all the solutions required for the installation (incorporation) of your stove.

The responsibility of the installer is to ensure that the stove is in compliance with local regulations applicable in the place where the stove is installed (incorporated).

The use of the stove must be in accordance with the instructions given in this Manual for use and maintenance, as well as with all the safety standards prescribed by local legal regulations applicable in the place where the stove is installed (incorporated).

The installer must **verify (confirm)**:

- The type of the stove that is being installed,
- Whether the room in which the stove is being installed is appropriate, which is expressed as the minimum size of the room required for the installation as prescribed by the stove manufacturer,
- Instructions of the heat generator manufacturer, related to the requirements of the smoke discharge system (smoke discharge ducts and pipes),
- The internal cross section of the chimney, material the chimney is made of, cross-sectional uniformity, whether there are any obstacles and barriers in the chimney,
- The height and vertical extension of the chimney,
- The height above the sea level at the place of installation/incorporation,
- The existence and suitability of a wind resistant protective cover of the chimney,
- The possibility of providing the external air intake and the size of required openings,
- The possibility of the simultaneous use of the stove which is to be installed, together with the other equipment already existing in that place.

If the results of all the checkups are positive, then the installer may proceed with the incorporation/installation of the stove. The instructions provided by the stove manufacturer, as well as the fire prevention standards and safety standards must also be observed.

When the installation is completed, the system must be put into a trial operation for at least 30 minutes in order to check up all the packing and seals of the system.

When the incorporation and significant details are completed, the installer is obliged to provide the client with the following:

- The Use and Maintenance Manual issued by the stove manufacturer (if such a manual has not been delivered with the stove),
- The documents required for the compliance with existing standards.

3. STOVE INSTALLATION

When installing the stove, pay attention to the applicable regulations relating to the applicable construction and fire-fighting regulations and provisions.

Connection of the stove to the chimney is lateral, rear and up left or right. Depending on whether you have opted for a "left" or a "right" stove. Ensure that the place you are installing the stove is horizontal. If the floor is flammable (wood, plastic, carpet ...), use a sheet of steel, copper or other non-combustible material. This underlay should exceed the basic outlines of the stove by at least 30 cm on the sides and 50 cm on the side intended for manipulation. The distance of all sides, in relation to the parts of the furniture made of wood or plastic, is 20 cm as a minimum **and laterally should be 30 cm**. Built-in components made of combustible materials should have a distance of at least 80 cm from the opening for refilling the stove on the sides.

A safe distance from the objects that have to be protected (walls that may be set on fire, kitchen cabinets and loadbearing walls made of steel reinforced concrete) is minimum 20 cm and laterally 30 cm. A sufficient distance should be kept around the stove in relation to combustible items (which have a wooden layer, furniture, curtains, etc.). When using the steel plate of the stove, upgrades above the stove are not allowed. When moving the waste gas flue pipe, a minimum distance of **40 cm** should be kept in relation to combustible materials.

Before connecting the stove to the chimney, a chimney sweeper has to be consulted. Connection of the stove to the chimney should be made with the appropriate connecting parts and in accordance with SRPS.M.R4.031 (DIN 1298.ili DIN EN 1856-2).

The chimney plug and the flue pipe must not enter the cross section of the waste gas chimney and should be sealed mutually.

Generally, attention should be paid to DIN 18 160.

For measurement of the chimney, EN 13 384 is applicable.

If your stove is to reach the desired capacity, you should pay attention that the installation is correctly carried out and, above all, that the chimney functions flawlessly. In any case, you should check the existing pressure in the chimney before putting the stove into operation. The easiest way of checking the strength of the chimney draft is if you hold a candle flame under the chimney opening. The draft is sufficient if the flame of the candle sways towards the chimney opening. Poor swaying of the flame is a sign of poor draft. If two firing units are installed on one floor and on one chimney (multiple load), the distance between the connections may not be less than 50 cm.

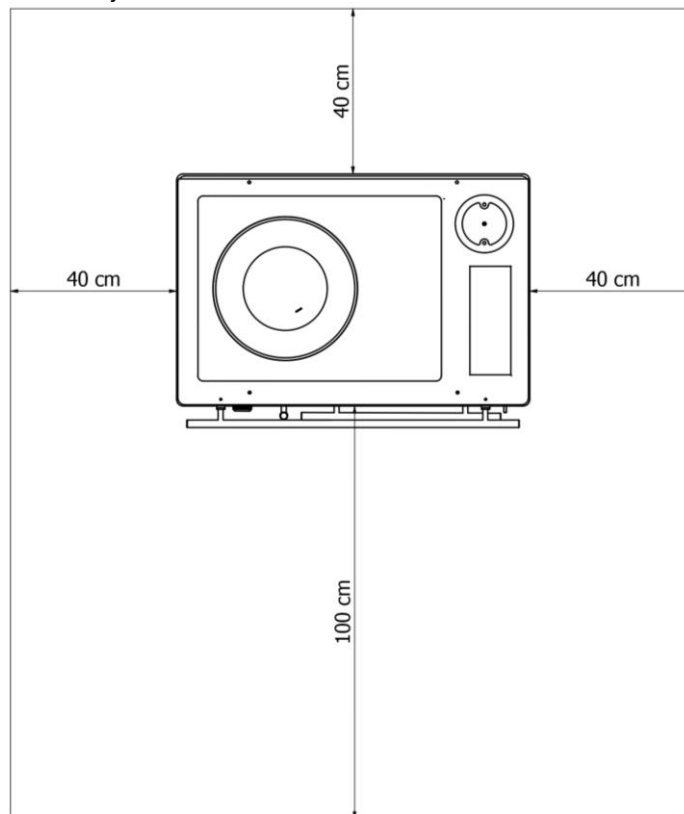

All minimum safety distances are indicated on the product data plate, DO NOT use lower values than specified (see INFORMATION ON CE MARKING).

3.1. AIR USED FOR COMBUSTION

Combustion air must be supplied to the rooms where the range is installed. The room must be constantly ventilated. A fresh air opening must be located in the lower part of the room and air should enter through it.

A) Supply of combustion air by means of a pipeline through the basement. This connection option leads to a preheating of the combustion air, which is useful for a good and clean combustion. The installation of pipelines in the basement is simple.

B) Supply of combustion air through the basement. The combustion air is preheated. The basement space must be separated from the ventilation system of the house and open to the outside. High levels of dust and moisture should be avoided.

C) Supply of combustion air from above. Air supply from above can only be performed with tested chimney systems.

In this case, it is necessary to calculate the dimensions of the chimney!

D) Supply of combustion air directly from outside. If combustion air is directly supplied through the outer wall, it shall be only be slightly preheated, which is unfavorable for a clean combustion. In this case there is also risk of condensation!

NOTE: We do not recommend these versions of air supply! However, if you use these options, consult a qualified professional.

In the room where the heating device is installed, it is necessary to ensure sufficient supply of fresh air. If the windows and doors are hermetically sealed or if there are air-extracting devices, such as hoods, hair dryers, fans etc., in the room where the range is installed, combustion air (fresh air) must be supplied from outside. In any case, this should be discussed with a competent chimney sweep before installing the range.

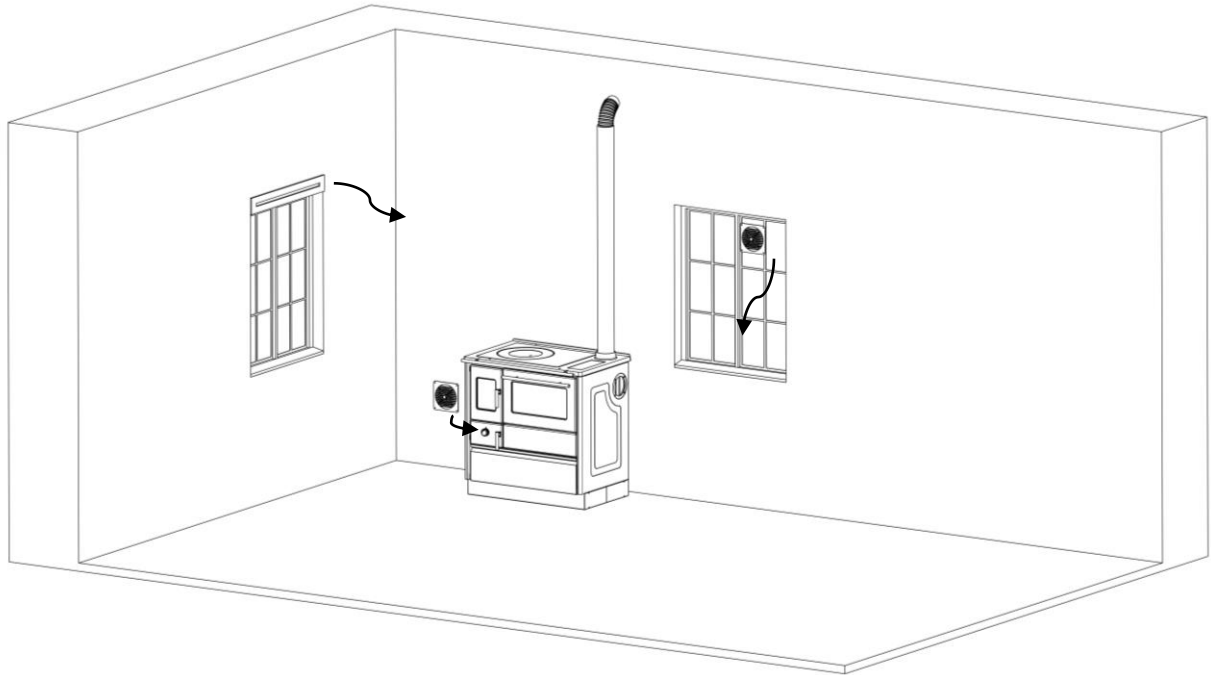

Supply of fresh air in the room where the range is installed

4. INSTALLATION TO THE FLUE

Inspect the unpacked stove and get acquainted with the parts of the stove and accessories, and pay special attention to the following:

- The door must be well sealed, and the lid is on the hob so to prevent uncontrolled air inflow into the stove.
- The power regulator must open and close the regulator valve properly by using the regulation knob (Figure 1 pos. 3).
- The flue connection must be well sealed with asbestos-free tape during relocation to side or back, which depends on the position in relation to the flue.

SPECIAL CONSIDERATIONS

- The flue connection should be placed upwards;
- The flue connection, flue pipes and the flue must not be narrowed;
- All connections, as well as the flue must be well sealed, without soot and dirt in the flue ducts.

The corresponding flue and meeting other requirements are a precondition for flawless stove functioning.

The stove can be installed in the kitchen or other suitable place, taking care that a non-flammable base is placed under the stove, and if the floor is hardwood, then place a special sheet metal plate which will prevent damage to the floor and fire due to careless handling.

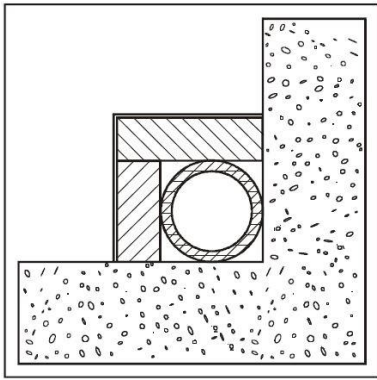

AISI 316 steel chimney with double insulated chamber, made of material resistant to 400°C. Optimal efficiency 100%

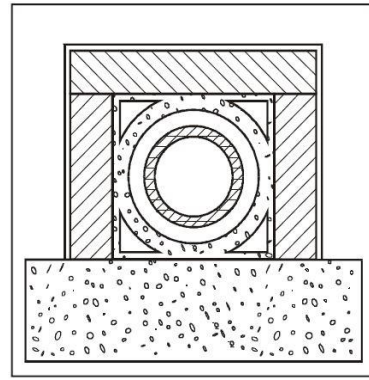

Fireproof chimney with double insulated chamber and an outer lining of lightweight concrete. Optimal efficiency 100%

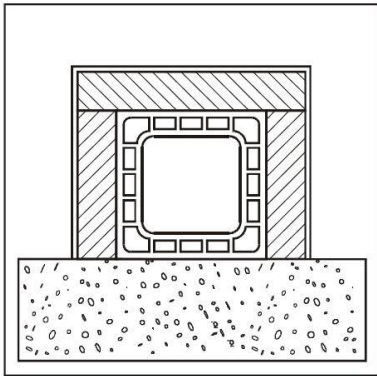

Traditional clay chimney with recesses. Optimal efficiency 80%

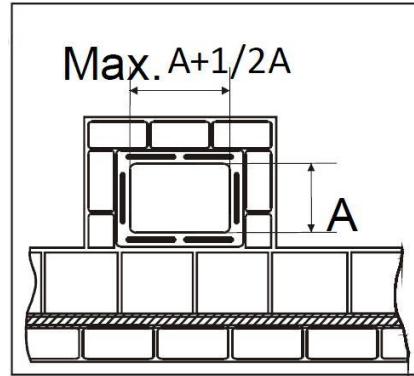

It is forbidden to use chimney pipes that have a rectangular internal cross-section with a ratio that differs from the plan. Modest efficiency 40%

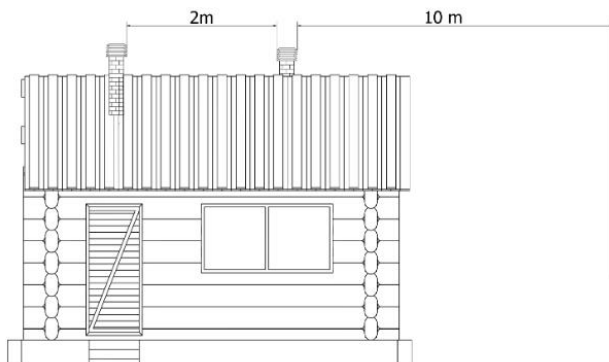
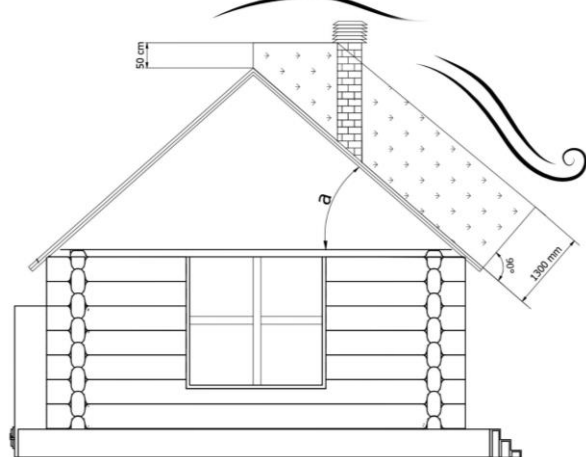
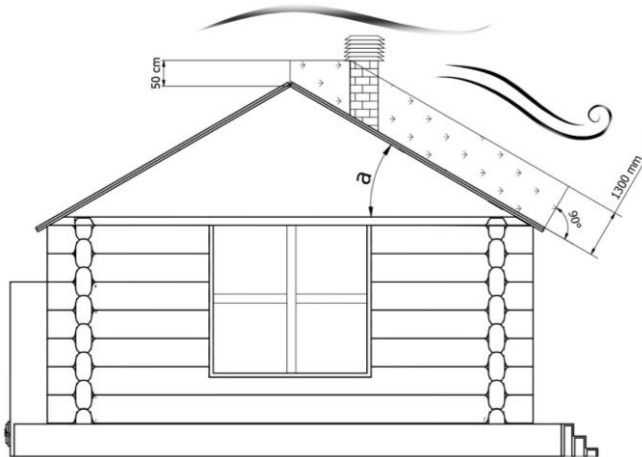

Chimney - positioning and distance

5. HANDLING

5.1. HANDLING OF THE FIREBOX DOOR HANDLE

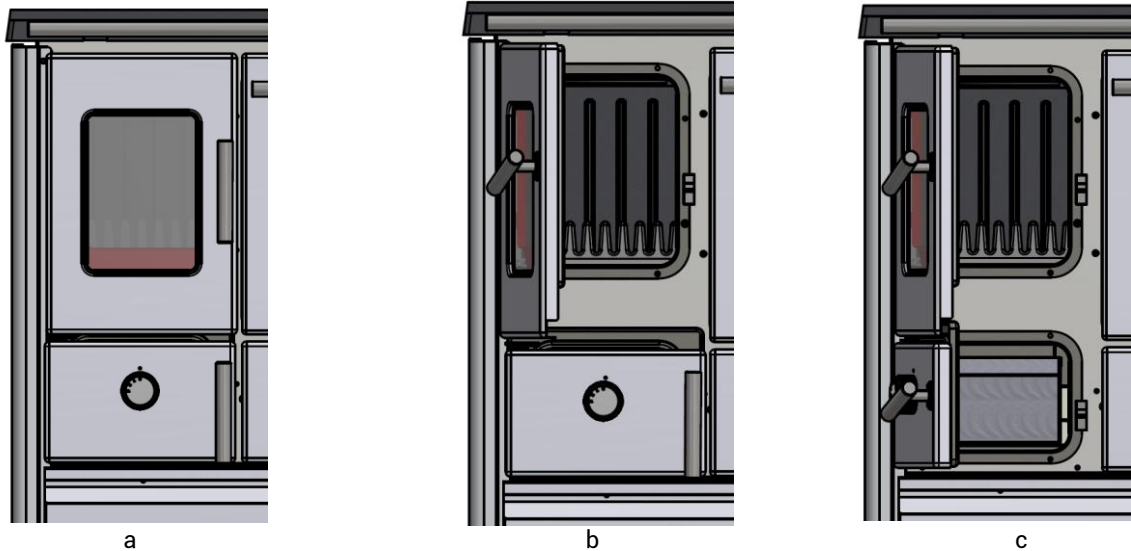

Figure 2

Open the firebox door by turning the handle clockwise for 90° and pull it toward yourself (see Image 2).

The ashtray door can be opened only when the firebox door are opened. Turn the ashtray door handle clockwise for 90° and pull the door in order to take out the ashtray and dispose of the accumulated ash, clean the ashtray and place it back. WHEN CLOSING, FIRST CLOSE THE ASHTRAY DOOR AND THEN THE FIREBOX DOOR.

5.2. AIR CONTROL

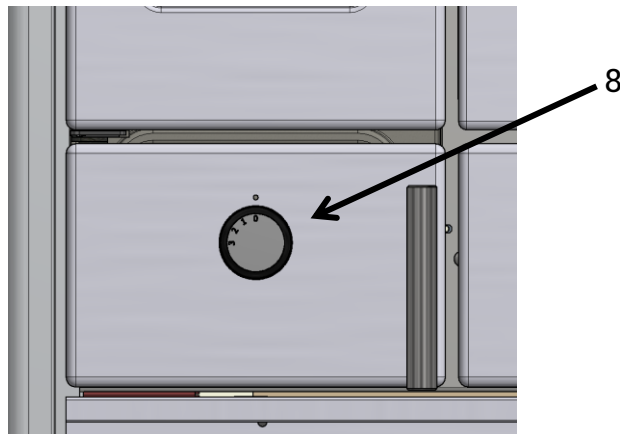

Figure 3

5.2.1. PRIMARY AIR

The primary combustion air and thus the heating capacity of the stove is determined by the primary air for combustion. This air is controlled by the primary air control on the ashtray door (Fig. 1, item 3). The button on the ashtray door (Fig. 3, item 8) shows the direction of the opening and closing the slide opening. For firing, the air control should be opened to a maximum (set the button to the position 3).

Note: To prevent overheating of the stove, the quantity of fuel must not exceed **2.05 kg** of dried wood or **1.325 kg of lignite briquettes** for each hour with the appropriately set combustion – air.

5.3. WARMING FLAP

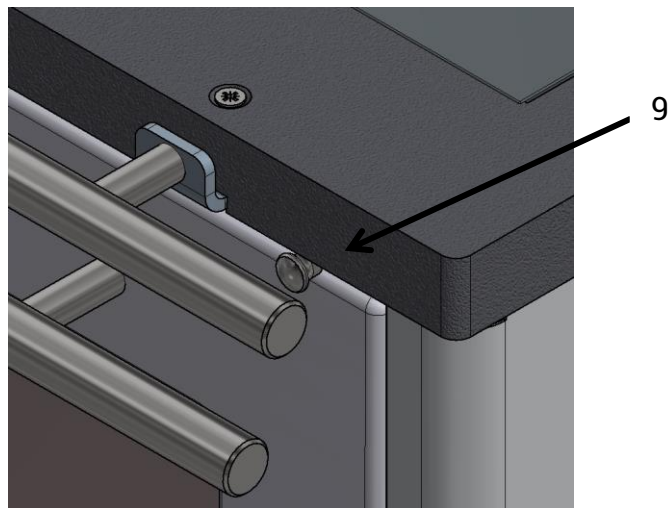

Figure 4

Moving of the warming flap is made by activating the button (Fig. 4, item 9) located above the oven door. It is used for shortening the paths of flue gases during firing.

The warming flap should be opened only in the phase of lighting the fire in the stove. During firing, the open warming flap leads to overheating of the stove and thus to damaging parts of the stove. In addition, the open warming flap results in increased consumption of fuel.

Pull the button out = the warming flap is open
Retract the button = the warming flap is closed

5.4. OVEN DOOR (Figure 1, Item 6)

The oven door may be in one of two positions as opted, depending on the desired heat required for the room.

Oven door open: higher heat emission for heating the room.

Oven door closed: lower heat emission for heating the room.

The oven door can be removed without using tools: take the door handle and pull upwards the door that is slightly open. Reinstallation is made by introducing both hinges into the corresponding openings, at the front of the oven, while placing pressure on the lower edge of the door with a knee and light pulling of the handle up. When the stove is in operation, the oven door must be installed.

5.5. FUEL DRAWER (Figure 1, Item 4)

The lower part of the stove contains space for fuel, which has guides and is easily movable.

Warning: Do not store easily flammable matters like paper, etc. Pay attention to the height when loading.

6. COMMISSIONING OF THE STOVE

Before the first fire lighting, all enameled surfaces should be cleaned with a soft dry cloth in order to prevent the creation of stains. After acquaintance with the handling of the stove, the commissioning can follow. During the first lighting of fire, open the window as the applied protection from corrosion develops unpleasant but insignificant smoke, i.e. an odour for a short time. This is normal and disappears after a short while. Take into consideration that some in-built parts of the stove (pipe for waste gases, the loading door, etc.), when the stove is fired, can be heated and pose a risk of burns. Special attention should be paid to small children, in order to prevent their coming into danger. When firing the stove for the first time, fire it with two or three weak fires to avoid breakage of the fireclay.

6.1. LIGHTING THE FIRE

- * Pull out the button for the warming flap, the warming flap is open
- * Open the primary air control to the largest air release (Fig. 3, item 9)
- * Open the firebox door
- * Put wood wool, sawdust or paper
- * Put 2-3 small pieces of wood over it
- * Fire it
- * Close the firebox door
- * Let the wood burn briskly
- * Retract the warming flap, the warming flap is closed.

6.2. ADDING THE FUEL

After the basic embers are created, fuel should be added through the loading opening. Place the air control in the corresponding marked place (put the button in the position 1-3).

When adding the fuel, open the firebox door slowly to prevent escape of the flue gases, thus avoiding flue gases entering the room.

You will achieve the nominal heating capacity when you put the following fuel quantities and adjust:

Fuel	Fuel quantity	Combustion time	Adjustment of the primary air
Split firewood	2,41kg	1.0 h	Degree 1

Pay attention to never putting more firewood or lignite briquettes than are required for the nominal capacity of heating. The above quantities of fuel should not be exceeded as this may cause the stove to overheat.

Only naturally dried firewood or lignite briquettes may be used, in accordance with the regulation on protection from emission.

The firewood that is used must be dry (remaining moisture 20%). It is usually the case when the firewood is stored for two years in a dry place with good ventilation. Wet firewood has a low calorific value and leads to deposits of soot in the flue gas pipes and the chimney. Wood with a treated upper surface (lacquered, painted, laminated and impregnated, plywood, waste of any kind, garbage from packaging, plastics, papers, rubber, leather, textiles, etc.) must not be fired.

Combustion of such materials pollutes the environment and it is forbidden by the legislator. In addition, damages can occur in the chimney. In such a case, all types of warranties by the manufacturer become invalid. Under unfavorable conditions of the draft in the chimney, problems can arise because the flue gases are not completely evacuated. In any such case, fire as a bait in the chimney should be made. If this measure does not create draft in the chimney, the operation of the stove is not allowed for safety reasons.

Note: Better use of the fuel and thus better heating of the room is achieved by opening the door of the oven slightly or completely.

6.3. COOKING

The stove is equipped with a grid for working in winter and in summer.

To move the grid from the lower to the upper position, the grid is pushed backwards and lifted. In the inclined position, remove the lever of the shaker and then remove the grid through the space for loading.

Afterwards, the carrier of the grid is lifted and pulled out. The mounting parts of the grid can then be placed in the upper position in the reverse order. The lever of the shaker is led to the frontside of the stove in the upper duct and lifted up through the space for ash so that the tooth of the grid is blocked in the opening of the shaker lever.

6.3.1. COOKING IN THE SUMMER

During hot days, the solid fuel stove is used mainly for cooking. The oven door is kept closed. It is preferable to use a pot with a thick bottom and an appropriate lid.

6.3.2. COOKING IN THE WINTER

During cold days, the solid fuel stove is used mainly for heating rooms. For faster cooking, dry firewood is used. The warming flap must be closed and the air control opened to the maximum.

When cooking is completed, the air control should be placed to the marked position for the nominal heating capacity.

6.4. BAKING CAKES AND ROASTING

Baking cakes and roasting require evenly distributed heat.

In order to achieve the evenly distributed and sufficiently high temperature, the oven must be closed with the closed warming flap and, depending on the type that is baked, it should be heated in advance. If the stove is heated to the desired temperature, put what you are baking in the oven. Do not allow creation of very strong embers, but constantly add fuel in small quantities. Place high cake moulds into the lower groove of the oven. All cakes that have such a form should be baked at a moderate temperature. For flat cakes and pastry, you can use both grooves. For this, slightly higher temperature is recommended.

For roasting, you need a significantly higher temperature than for baking cakes. Thus, the preparation time (heating in advance) is somewhat longer and necessary.

6.5. FIRING THE STOVE IN THE TRANSITION PERIOD

When the outside temperatures are above 15°C, based on the small transport pressure, a small fire occurs in the chimney. This fire creates more soot in the stove flue pipes and the chimney. Increase the supply of the primary air and poke the embers of the fire and refill fuel (small pieces of split firewood) more frequently in order to reduce the soot in the transition period.

7. MAINTENANCE AND CLEANING OF THE STOVE

Regular maintenance and care, such as cleaning of the stove, stove flue pipes and chimney extensions are very important for safe work, cost-effectiveness and keeping of the stove value.

Maintenance of enameled surfaces of the stove is recommended only when the stove is cold. **Clean the stove with clean water and soft cloth, and in special cases with soapy water.** Cleaning intervals mainly depend on the use of fuel, on the length of time in which the stove has been used and the manner of use. Unnecessary creation of dust may be avoided if the following order of cleaning is observed.

- * Removing the hob and its thorough cleaning outside.
- * Cleaning the soot and deposits on the upper side of the stove and the places through which the flue gases pass.
- * Installation of the plate
- * Opening the protective cover for cleaning (below the oven door) and removal of the cover
- * Removing soot and ash from the partition sheet
- * Removing soot and ash from the bottom of the stove
- * Fastening the cover on the front side and closing the protective cover.

7.1. OPENING FOR CLEANING

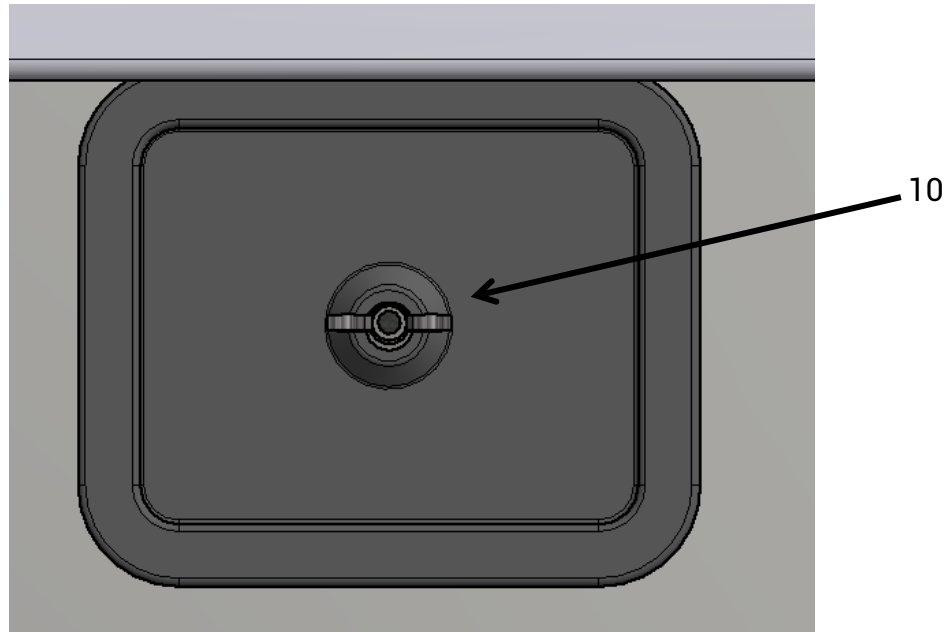

Figure. 5

There is a cover (Figure 5, item 10) behind the protective cover of the opening for cleaning. The cover is fixed with one butterfly screw on the front side of the stove and in order to clean the inside of the stove, it should be removed. Before screwing it again, the sealing braid that is on the cover should be controlled for sealing and, if necessary, it should be replaced.

7.2. MAINTENANCE AND CLEANING OF THE COOKING PLATE

The hotplate is made of grey casting and enamelled, which makes it easy to clean. First wipe it with a damp cloth and then with a dry cloth. Do not use sandpaper since it can damage the enamel. The hotplate is not enamelled from the inside, so you can remove the soot and ash deposits with a coarse brush.

7.3. REMOVAL OF SLAG AND ASH

Slag is removed with the supplied tool, through the slide opening. The ashtray should be emptied regularly, every time before lighting the fire. 1 - 2 times a week the grid should be cleaned. If the air vents are clogged with slag, baked crust or other burnt residues, completely remove the grid and clean it.

7.4. GENERAL NOTES

If you observe the instructions for installation and handling, the stove is a reliable home appliance. All defects on your stove can be rectified by our customer service team.

When lodging complaints regarding faults or defects arising in connection with the functionality, please contact our customer service team. They can also assist in the procurement of spare parts (use only original parts).

The entire firing appliance must be regularly checked by an expert.

8. DETERMINING THE REQUIRED HEAT OUTPUT

There is no absolute rule that would allow the calculation of the required heat output. This power is determined by the space you want to heat, but it also largely depends on the insulation. On average, the required heat output for a properly insulated room would be **30 kcal h per m³** (at an outdoor temperature of 0°C).

Fuel	Unit	Indicative combustion value		Required quantity in the ratio of 1 kg of dry wood
		kcal/h	kW	
Dry wood (15% moisture)	kg	3600	4.2	1.00
Wet wood (50% moisture)	kg	1850	2.2	1.95

9. TURNING THE APPLIANCE OFF

In the event of fire or overheating, close the air inlet covers and DO NOT open the fireplace door. Extinguish the fire with appropriate means (home fire extinguisher...). NEVER USE WATER TO EXTINGUISH THE FIRE! Also notify local firefighters in case of fire. Follow local fire protection regulations!